



LED Module

# EdiCube

## IP65

-Series

Brighten your Life

Light illuminates our lives and changes the way we live

**Edison** Opto never stops pushing back frontiers to develop the perfect LED products for emerging solid state lighting applications.

As a socially responsible LED manufacturer, we expect to not only enrich our lives, but also promote a better living environment for the global community.

www.edison-opto.com

**EDISON** Opto Optoelectronics Technology

*IP65 EdiCube module features excellent dust and water proof performance. With secondary optical lens, Edison IP65 EdiCube Series delivers outstanding light uniformity and wide emitting angle which is up to 160°. Besides, every single module can be connected and molded into all shapes for various applications. It is the best solution for advertising light box and channel letters.*

### Features and Benefits

- Thin and light design
- Wide angle 160°
- Uniform brightness
- IP 65 waterproof and thermal design

### Main Applications

- Advertising light box

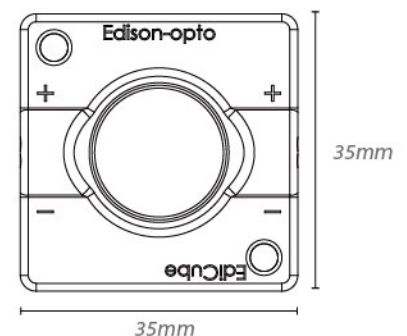
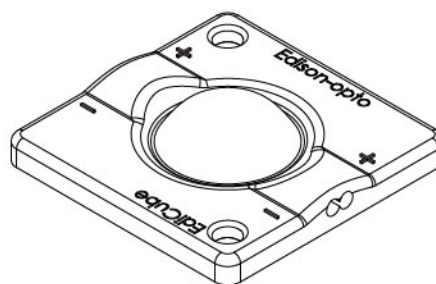

Type	LEDs (pcs)	Power (W)	VF (V)	IF (mA)	CCT (K)	Typ. Flux (lm)	CRI	Size (mm)
Module	1	1.2	12	110	5700~6000	90	80	35x35
Chain	30	39		3300		2700		5550x35